

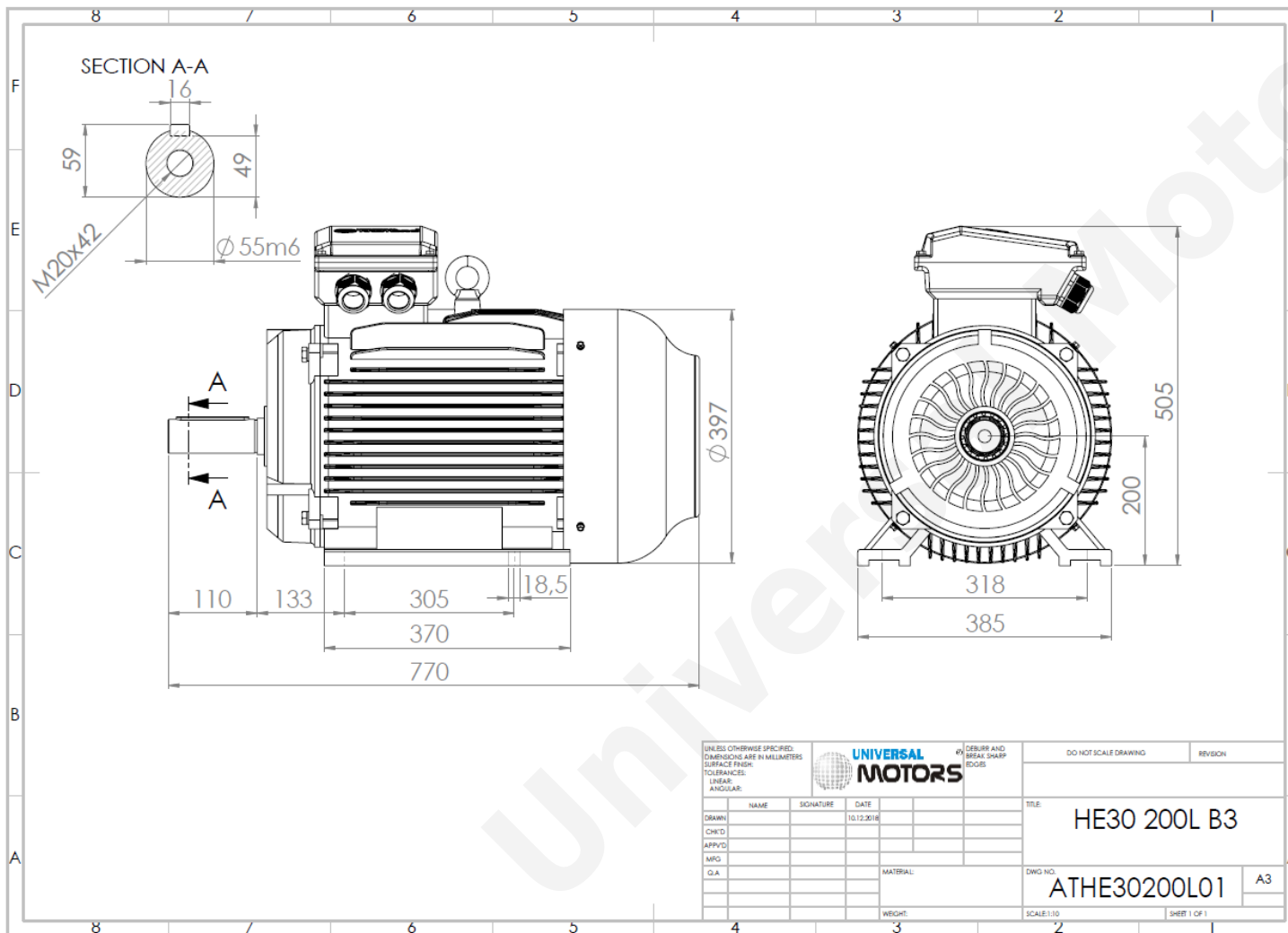

TECHNICAL DATA

Three Phase Electric Motors - Cast Iron Frame
 HE30 200 L-2 IE2
 30 kW / 40 Cv
 2960 RPM



Motor type:	HE30 200 L-2 IE2
Output:	30 kW / 40 Cv
Speed (min ⁻¹):	2960 RPM
Frequency:	50 Hz
Voltage:	400 V
Current:	52.9 A
Power factor (Cos Ø):	0.89
Poles:	2
Insulation class:	F
Temperature rise Class:	B
Efficiency 50%:	91.1 %
Efficiency 75%:	92.4 %
Efficiency 100%:	92.0 %
Torque:	97 N.m
Tstarting/Tnominal:	2.2
Istarting/Inominal:	7.5
Tmaximum/Tnominal:	2.3
Noise:	73 Db(A)
Weight:	243 Kg
Bearing DE:	6312 C3
Bearing NDE:	6312 C3

Regime - S1

Altitude - 1000m

Environment Temperature - 40°C

CONTACTS:

UNIVERSAL MOTORS Tel: +351 252 299 080
 Rua de São Brás,745 Fax: +351 252 299 089
 4480-782 VILA DO CONDE Mail: geral@universalmotors.pt

* References applied only in the UK